



Functional specification of an electric car

Authors/ Executors:

Team from ZSS (Automotive Group of Schools):

Kwaśniewski Andrzej, Marek Gabrylewicz, Przemysław Polowczyk , Jan Michalski., Mirosław Pietrasz

Team from Poznań University of Technology (PUT):

Jerzy Kupiec, Grzegorz Ślaski, Ryszard Mańczak



Dieses Projekt wird durch das Programm Erasmus+ der Europäischen Union gefördert. Der Inhalt dieser Veröffentlichung gibt allein die Meinung des Verfassers wieder. Die Nationale Agentur und die Europäische Kommission haften nicht für die Nutzung der enthaltenen Informationen.

Contact data:

ZSS (Automotive Group of Schools):

Zespół Szkół Samochodowych im. Tadeusza Tańskiego w Poznaniu

E-mail: auryn11@wp.pl

Poznań University of Technology (PUT)

Address:

Politechnika Poznańska

Instytut Maszyn Roboczych i Pojazdów Samochodowych

ul. Piotrowo 3

60-965 Poznań

E-mail: jerzy.kupiec@put.poznan.pl

Table of contents:

List of abbreviations

1. Introduction	5
2. The starting point.....	6
3. The aim of the project.....	11
4. The requirements of the final product.....	11
5. The general structure of electric – powered car.....	11
6. The concept of the measurement of the powertrain.....	16
7. The range of exploitation.....	19
7.1.The range of construction and operation.....	19
7.2.The range of diagnostics.....	19
7.3.The range of repairs.....	20
7.4.The range of diagnosing the powertrain.....	20
8. The list of requirements.....	21
9. The criteria of accepting the final product.....	21
10. Planning and implementing the project’s effects.....	22
11. References.....	23
12. Annex.....	23
13. List of figures.....	23

List of abbreviations:

BLDC - BrushLess Direct-Current motor

PMSM - Permanent-Magnet Synchronous Motor

EV – Electric Vehicle

BMS – Battery Management System

PWM - Pulse-Width Modulation

1. Introduction

In the times of unstable fuel prices and the increasing role of ecology the electric cars were the ones that were supposed to win the automotive market in Poland. This however, did not happen. In 2013 Polish drivers bought only 32 EV which is comparable to the sale result in previous years. When buying a car people usually take into account its basic parameters such as: price, range, fuel consumption, the cost of maintenance and the anticipated residual value (resale value). Most of these parameters for an electrical vehicle have lower values and performance. The leader on the Polish market Mitsubishi i-MiEV (total number of sold cars 24 over 3 years) costs 160 000 PLN. With this price the customer gets the range up to 150 km, maximum speed of 130 km/h and battery charging time of 6 hours. What should be however underlined is the fact that EV does not consume expensive fuel and a single charging for example in France costs only about 2 euros. So far, it is impossible to estimate the residual value of the car (the first leasing contracts for EV in Poland are just about to be finished), but in Great Britain leasing companies estimate this value at zero pounds.

The niche on the market that electric vehicles fill quite successfully is the public transport. In September 2011 Solaris Bus and Coach Company located nearby Poznań presented a prototype of a bus with electric drive called Solaris Urbino electric. Japanese Toyota has started an innovative 3 – year program that enables on the basis of car – sharing renting a two-person electric vehicles i-ROAD in the French city of Grenoble.

The rising market of electric vehicles means that in the near future there won't be enough qualified specialists in the field of maintenance, repair and diagnostics of such vehicles.

To sum up, despite all their drawbacks, there are more and more electric vehicles. Garages need more employees trained to maintain and repair cars powered by electric and hybrid engines. That is the reason why all the schools educating the following professions:

Vehicle Technician

Vehicle Mechanic

Vehicle electromechanic

are forced to modify curriculum, adapting it to dynamically developing cars powered by electric and hybrid engines.

Nowadays there many socio – economical changes influenced by globalization of economic and social process, geographical and professional mobility, new technologies and techniques, as well as higher expectations of employers concerning the knowledge and skills of their employees. The main aim of vocational education is to prepare students to live in the modern world, performing their job and being active on the constantly changing job market. It also forces schools to introduce information and constant evaluation of vocational curriculum. Changing conditions and expectations of the automotive market, the introduction of alternative sources of power in vehicles, makes it necessary to include into curriculum of schools teaching professions connected with automotive industry issues connected with hybrid and electric powertrain.

However, in order to adjust the curriculum properly as well as to teach on a high level it is necessary to construct a model of a didactic vehicle that contains all the structural elements of electric vehicle vital for training. The vehicle itself should be constructed within the cooperation of a few entities: vocational school, university and production plant represented by The Trade Chamber.

2. The starting point

Meeting the expectations of the developing market of electric vehicles it has become a necessity to construct a car with electric powertrain that could be used to teach future mechanics, technicians and engineers. To fulfill this aim ZSS (Automotive Group of Schools) bought a second-hand car Toyota Starlet with the intention to change its powertrain from combustion engine into electric one. One of the reasons for choosing this car was its low weight (760 kg) which means better performance after the changes. What is more, the car was cheap (2500 PLN) and in a very good mechanical and car body condition. All the jobs connected with adjusting the car to be powered by electric engine were performed in the workshops of ZSS (Automotive Group of Schools). First of all it was necessary to remove the combustion engine including the radiator, silencers, air filter, alternator, and engine control unit and fuel system including the fuel tank. The next step was to weld the containers for electric batteries instead of the fuel tank (under the back seat) and in the trunk.

There are a few kinds of electric engines to power vehicles: direct current (DC) engine and alternating current engine (AC). When making the analysis which one to choose to adapt the powertrain in Toyota Starlet it was necessary to consider different kinds of electric engines and technical possibilities to do it in the workshops of ZSS (Automotive Group of Schools). What is more, also the financial aspect connected with the purchase of electric engine and batteries had to be taken into account. Below it has been presented the analysis of selecting the motor to be used in Toyota Starlet bought by ZSS in Poznań (Automotive Group of Schools).

The analysis of selecting the motor to power Toyota Starlet:

The designers of electric vehicles at some point of their work must face a question of which motor to choose to power electric vehicle? To construct electric vehicles the following motors can be used:

Direct current (DC) motors:

- brushed electromagnet electric motor,
- brushed permanent – magnet electric motor,
- brushless DC electric motor (BLDC)

Alternating current three-phase motors (AC):

- asynchronous squirrel-cage type,
- Permanent Magnet Synchronous Motor (PMSM)
- synchronous switched reluctance motors.

All of the motors above can be used to power electric vehicles both for direct drive and indirect drive with the use of transmission. It is important to choose proper motor power, rotation speed and moment. The choice of motor influences the vehicle performances.

The direct current (DC) motors do not require power inverter, they can be directly supplied from switched batteries or using the starting resistors. This solution however, is not practical and it makes it impossible to shape the parameters of the powertrain. Each of alternating current motors require a microprocessor-steered power inverter which enables to shape the parameters of the powertrain of electric vehicle freely.

Brushed permanent – magnet electric motor have higher than magnetless motors but only with the speed range from 0 to nominal rotation speed. Within this speed range the motor does not need current from the batteries to propel the engine. Unfortunately, if we want to force speed higher than nominal rotation speed then the efficiency of permanent-magnet motor decreases (Figure 1). With speeds higher than the nominal rotation speed which means second sphere of regulation it is necessary extra current form the battery that will create magnetic flux that weakens the flux originating from permanent magnets. Properly chosen motor to power electric vehicle should be able to work within two regions of regulation: in region I below the nominal rotation speed and in region II over the nominal rotation speed. It will enable to adjust the motor to the characteristic of moment of resistance proper for a vehicle.

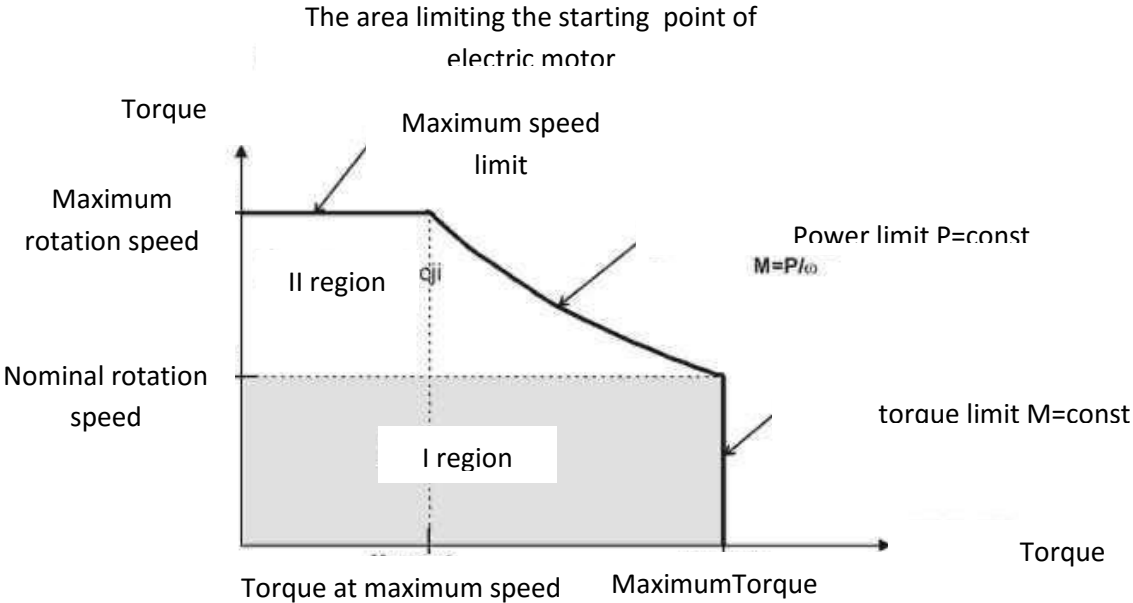

Fig.1 Regions for electric motor.

The actual starting point of electric motor results from set speed of vehicle and present moment of resistance that is the resistance that the vehicle encounters. With the speed lower that nominal rotation speed, the starting point of electric motor on mechanical characteristic is limited by the maximum torque, it means work area with constant moment. With the speed higher than nominal rotation speed, the starting point of electric motor on mechanical characteristic is limited by the maximum motor power and on mechanical characteristic it is limited by a curve described by the equation:

$$M = \frac{P}{n}$$

where n means motor speed at constant power $P = \text{const.}$

When considering the acceptable motor work area, it must be taken into account that this motor work area can change due to the fact that electric motor can be overloaded. Motor catalogues present the values of motor overloading and estimate the time how long the electric motor can be overloaded. For example for asynchronous squirrel-cage type motor the overload is 3 times the value of nominal motor torque. The graphs for the region changes under overload for synchronous and asynchronous motors are presented in figures 2 and 3.

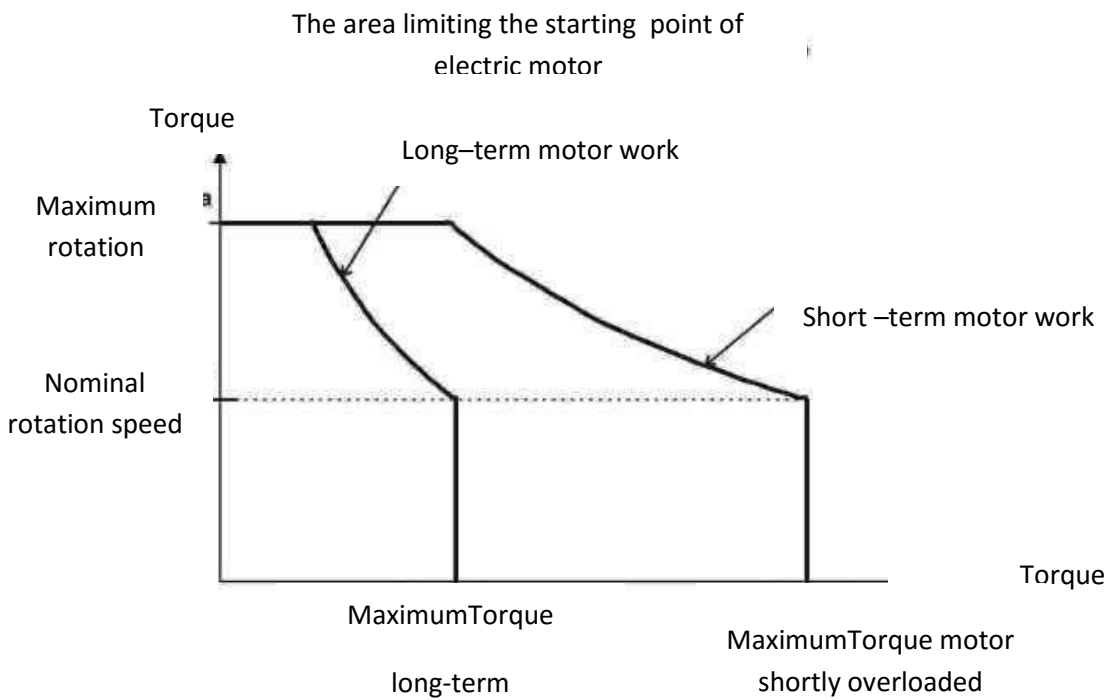

Fig 2. The graph of region changes under overload for synchronous motors.

Entering the II region makes the steering system more complicated but if we give up high rotation speed, then the motor used in vehicle will be oversized which means too big and too heavy.

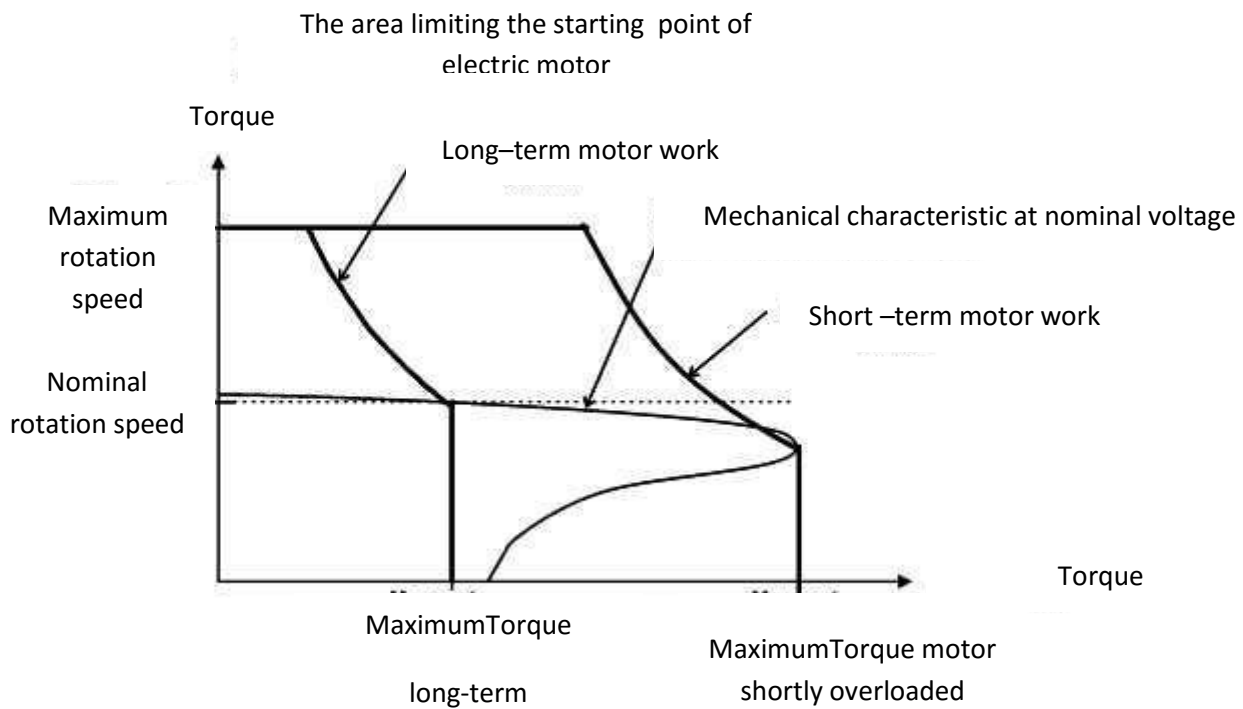

Fig. 3 The graph of region changes under overload for asynchronous motors.

- Deducing from the graphs a classic asynchronous motor seems to be an interesting alternative. This motor's efficiency is about 80 % but there are also available the ones with over 90 % efficiency. Taking efficiency into account it is clear that Permanent Magnet Synchronous Motors (PMSM) are not so attractive especially if we consider their high price when compared to asynchronous squirrel-cage type motors. As far as motor's voltage is concerned, every motor can be coiled in such a way to adjust it to the voltage level from batteries. However, the cheapest solution is to use motor with standard supply voltage. It seems the easiest to use batteries with voltage 300V and standard asynchronous squirrel-cage type motor 380/220 connected in a triangle. Then it makes it possible to use standard inverter with IGBT transistors to supply asynchronous squirrel-cage type motor. But it means the costs of purchasing the inverter and regulations connected with the handling of high-voltage appliances

3. The aim of the project

The aim of the project is to construct such an electric vehicle that will enable to prepare didactic materials, that will later be used to teach a profession in line with modern technologies contemporary demands and gaining skills form different professions.

4. The requirements of the final product

The final product is a vehicle with electric drive based on Toyota Starlet car, which will be used in teaching process in areas connected with construction, principles of operation, repairs, diagnostics and motor – starting.

The vehicle is assumed to an inexpensive construction based on quite modern technologies that will enable to fulfill the aim stated in point 3.

The vehicle will be used to create curriculum and training programs to educate vocational schools students, high schools students, university students and employees of automotive branch.

5. The general structure of electric – powered car

The term powertrain includes all the issues connected with supplying mechanical energy of different kinds of motors to machines. When we talk about electric motors it is electric powertrain.

The electric powertrain is a device that works according to the rule of using electric energy to make a machine move (i.e. pump, compressor, machine tool, industrial machine etc.) It usually consists of 3 parts:

- electric motor where electrical energy is converted into mechanical energy of a shaft or other part doing a translational motion.
- a part connecting electric motor with a machine such as clutches (with the direct connection of engine shaft with machine shaft), belts, transmission etc.
- electric apparatus used to connect motor to the grid, steer its work and protect from interferences.

All the components connected in accordance with a given diagram create electric powertrain (fig.4)

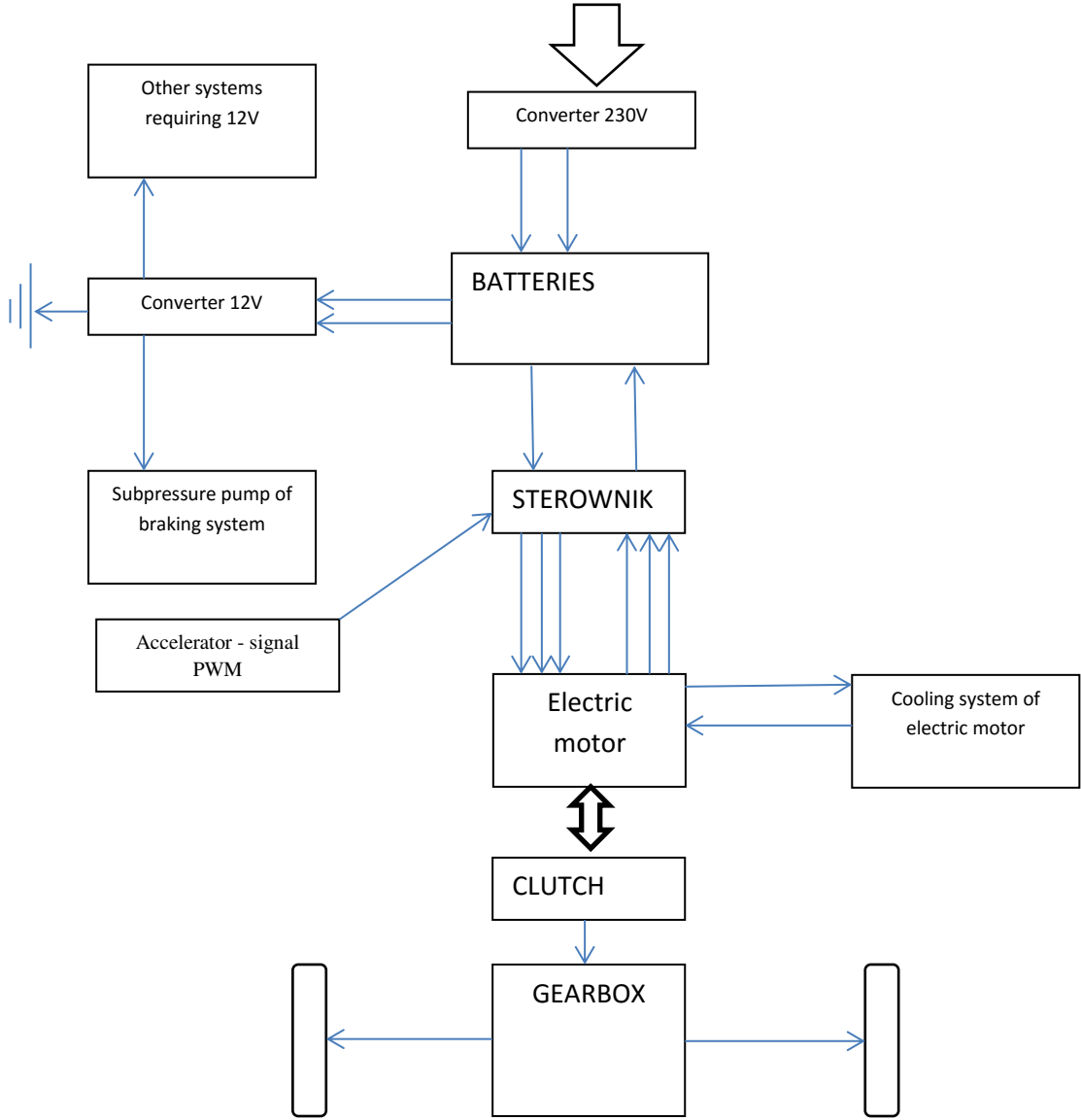

Fig. 4 The diagram of proposed electric powertrain.

As it was mentioned before to power the vehicle BLDC motor was used. It more widely used because of its high efficiency and high durability [1]. What is more, it doesn't require frequent maintenance and service and doesn't make a lot of noise. Its highest disadvantage is its price connected with the price of permanent magnets and the necessity of including electric commutator. The decreasing prices of

electronic components, large scale of integration of electronic systems of supply and steering as well as high costs of electric energy cause that a powertrain with BLDC motor is much more competitive in comparison to a powertrain with asynchronous squirrel-cage type motor. In a number of applications BLDC motor can be equipped with reliable, uncomplicated and inexpensive electronic commutator that is responsible for regulating rotation speed, change of direction of rotation and overload protection. Eliminating position sensors and links connecting them with the currently developing, sensorless steering systems increases its reliability and lowers the price of powertrain with BLDC motor.

Brushless DC electric motors (BLDC) exceed all the other motors due to their efficiency and power received from capacity or weight unit. What is more, the rotors of these motors show almost no losses as they are usually made of high resistance neodymium magnets. Most losses occur in stator, which can be easily cooled [3]. Stator's winding can be loaded with higher current density that allows minimizing the size of a machine. These motor do not contain a problematic and requiring a maintenance commutator, they work quietly and its durability basically depends on the durability of chosen bearings.

The advantages of brushless DC electric motors (BLDC) are:

- simple construction of the motor,
- high torque – motor weight ratio,
- high efficiency,
- simple steering system,
- wide range of rotation speed regulation.
- very precise rotation speed regulation without extra expenses,
- high starting momentum,
- low costs of maintenance,
- lack of brushes (the motor is quiet, reliable, with no sign of mechanical wear or conductive dust).

This engine also has some disadvantages. The most common are:

- electromagnetic momentum pulse
- high cost of permanent magnets,
- the necessity of using driveshaft sensors that increases the price of powertrain.

The construction of BLDC motor differs greatly from the constructions used in other electric machines. Its basic elements are rotor and stator. Unlike in traditional motors the rotor generates a uniform magnetic field originating from the permanent magnets. Stator's magnetic field is induced in windings connected in groups. The biggest advantage of BLDC motor is the fact a commutator does not have to be used; there is no occurrence of commutation or energy loss because of current flow through the brushes of high resistance. Fig. 5 shows a rotor and stator's winding and the way they are connected.

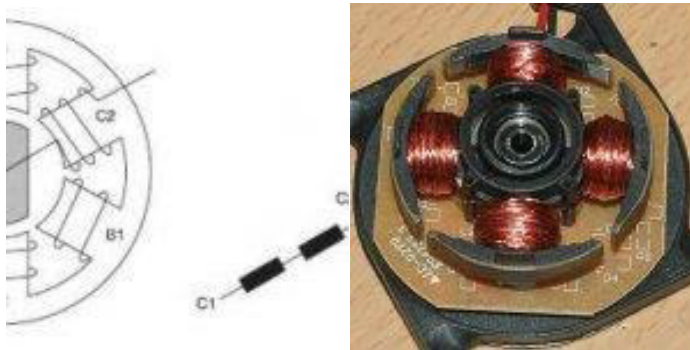

Fig. 5 The connection of rotor and stator's winding for BLDC motor.

Steering system is usually made us passed on switching transistor which number depends on the number of stator's windings. It is responsible for the regulation of rotation speed, regulation of acceleration and analyzing the data about rotor position coming from the feedback.

The problem with steering the BLDC motor is usually connected with describing the state of connectors which is used a source of information about camshaft position which enables to mark switch momentum. Marking the position can be done on the basis of signals coming from magnetic sensors called hall sensors, which are placed in gaps, arranged against each other by 120° (fig. 6) The advantage of such solution is the fact that the signals coming from the sensors are used, with a help of simple logical system, to steer the work of switches.

This kind of steering also has some disadvantages for example the presence of sensors which are very sensitive. It does not mean that it is difficult to steer BLDC motors. Apart from steering with the use of sensors there are also others. One of them is based on the currents and voltage coming from the motor's windings to calculate the moment of switching the connectors. Also a couple of other steering methods can be used.

First method uses the electro-motoric force induced in the stage of motor; it can be easily measured when the motor is off. It is also possible to this nominate the time of passing this force though zero point and by shifting these signals by $\frac{1}{4}$ of period and in this way to use it to steer the work of connectors. This method has however a very vital limitation because at idle the induced electro-motoric force equals zero what disqualifies this method.

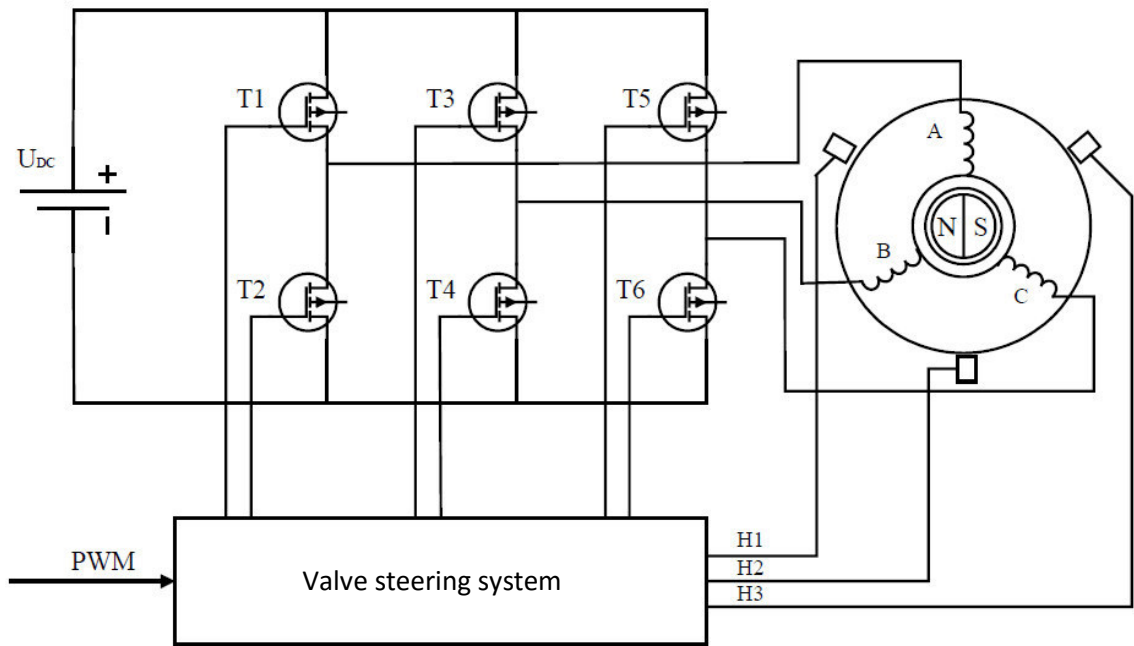

Fig. 6 Classic steering system of BLDC motor based on the measurement of rotor position with the use of Hall sensors (H1, H2, H3) [2]

The second method of sensorless steering of BLDC motor is based on the observation of the state of motor (Fig. 7) In that case a mathematical model is created which is being modified on the basis of signals of actual currents and voltages coming from the machine. This model also allows receiving signals enabling to steer the work of connectors.

Using the mathematical model has additional advantages because it shows additional physical data that can be used to steer the work of motor. Analyzing these data requires high computer performance.

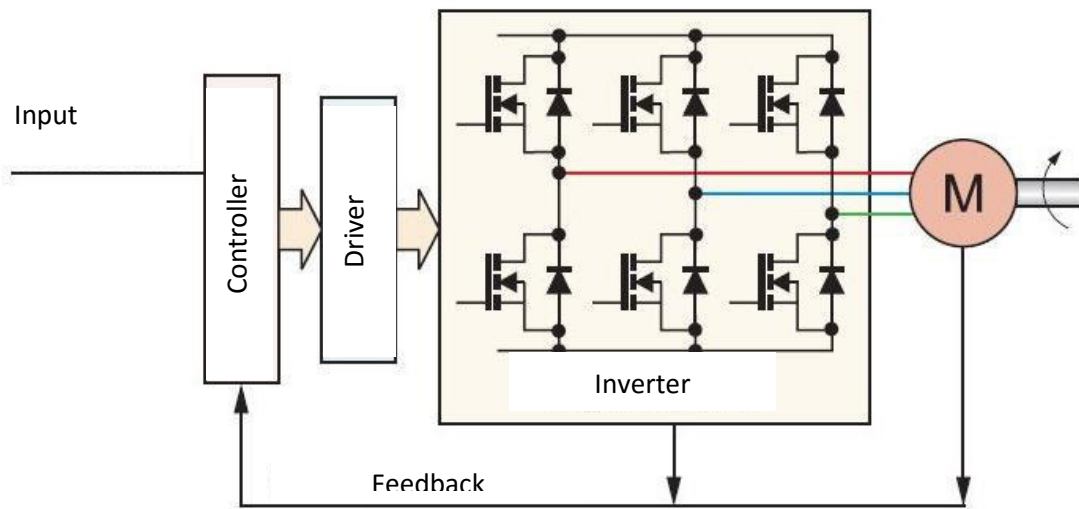

Figure 7: Diagram of sensorless steering of BLDC motor.

As far as power supply is concerned a 23 – cell battery set will be used with the voltage of 3, 2 V and capacity of 90 Ah made in LiFePo4 technology.

The characteristic features of these batteries are:

- long cycle life;
- high energetic efficiency
- short charging time;
- thermal and chemical stability.

6. The concept of the measurement of the powertrain

The constructed vehicle with electric powertrain should have in standard option at least one system to measure the consumption of energy by batteries, which replaced fuel gauge in standard vehicles. The necessity of using this vehicle for didactic purposes forces the use of more measurement systems. The diagram of the concept of the electric measurement of the powertrain is shown in fig. 8. It shows a graphic presentation of connecting particular parts of the powertrain including a schematic marking of points of applying the measuring

instruments. The use of particular measuring instrument is limited by the possibilities of connecting them to the electrical system of the car. In the diagram the multimeters have been marked with letters V, A to measure voltage and current intensity flowing in circuits and with letter W voltmeters to measure the consumption of electric energy. The way of connecting voltmeters is restricted to positive and negative wire, whereas ammeter depending on the possibility of access to measurement points: to stick in circuit, the measurements with the use of shunt or electric pincers. As far as connecting the wattmeter is concerned it should be done at power supply wire. All the measurement equipment was connected to one rail in order to be able to gather information from one terminal. It also makes it easier to connect to a device that would display and register the measurement data. This kind of device can be a PC computer with A/C converter card.

The terminal itself can have a form of universal plug or connecting rail. Each of the meters was marked with a different letter in order to identify its usage.

The usage of particular meters:

1. The measurements of supply voltage and current intake by the battery charging system while charging (expected values are 230V 16 A).
2. The measurements of voltage and current intensity and power intake while charging the batteries.
3. The measurements of voltage and current intensity and power used by motor.
4. The waveform of voltage and current intensity in a function of time for steering the electric motor.
5. The measurements of voltage changes in a function of time – oscilloscope measurements.
6. The measurements of voltage and current intensity and power intake by other devices in a vehicle.

The diagram also shows the marking of temperature sensors that should show the temperature of the motor and temperature in the cooling system.

The suggested concept does not deplete all the possible measurements; the only limit is the possibility of interference in electric system of part of motor and steering system

The alternative for such a solution can be an option to derive connections from particular powertrain parts onto one central board with banana connectors that enable direct measurements with the use of universal meters.

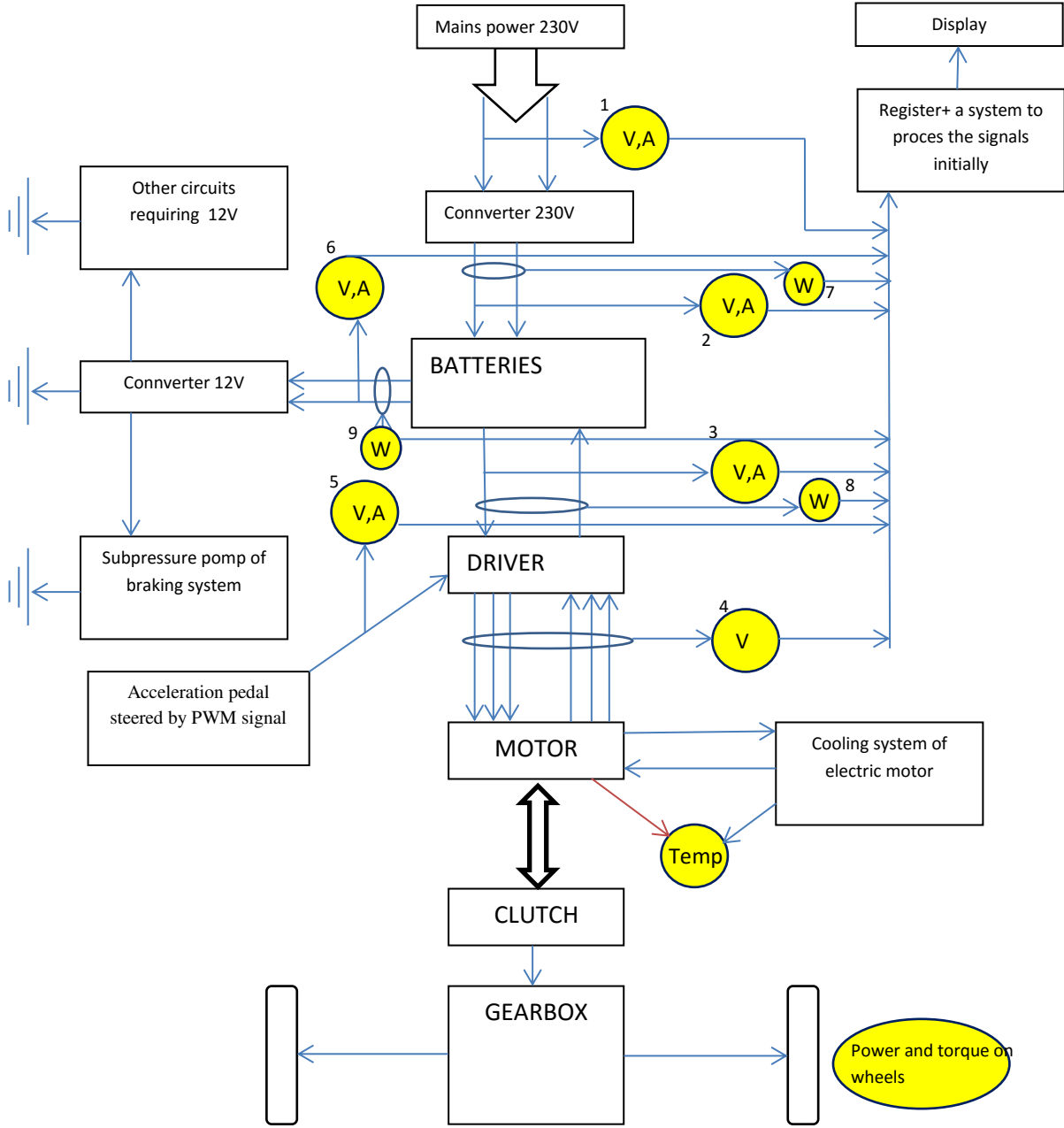

Fig.8. The diagram of connecting the measurement systems to electrical wiring of an electric vehicle.

The practical usage of proposed solution can concern issues connected with the diagnostic of particular systems, showing the principle of working and work stand and motor research.

The ideas of possible research have been presented in chapter 7.4.

7. The range of exploitation

A car with electric powertrain must be adjusted to be used in didactics and research; that is why it is such an important issue to describe the areas of its exploitation. Analyzing the requirements of teaching process a couple of basic areas concerning practical issues can be named:

- showing the construction and the principle of working of particular systems connected with the used powertrain;
- the diagnostics of elements characteristic of electric vehicle in the range of general and detailed, including electronic elements, diagnostics ;
- powertrain repairs by creating an easy access to particular elements;
- starting research with the use of engine test stand and registration equipment.

7.1.The range of construction and operation

Owing to a proper disposal of powertrain elements the vehicle will enable an easy access to electric system as well as mechanical. It essential to describe and show the proper position, assembly and working principles of such parts as: motor with cooling system, torque steering regulation system, battery set, battery charging system, etc.

7.2.The range of diagnostics

This area is much extended because it refers both to mechanical parts that are directly connected with the powertrain as well as electric elements. The diagnostics can be performed in the following laboratories:

- a) The laboratory of car diagnostics
 - The diagnostics of drivetrain (motor, motor cooling system)
 - The diagnostic of powertrain (clutch, gearbox)
- b) The laboratory of car electricity and electronics
 - The diagnostics of battery set (30 – cell),
 - The diagnostics of electric motor,
 - The diagnostics of speed controller
 - The diagnostics of electric elements present in cooling system, ventilation and heating system of a car and braking system.

7.3.The range of repairs

The repair of powertrain parts will include issues connected with the whole vehicle not only with the powertrain due to the fact that there were changes introduced connected with braking system, heating system and device supply system. That is why the topics from the range of repairs are as follows:

- the repair of electric motor (disassembly, assembly, measurements)
- the repair of powertrain (clutch, gearbox repair)
- the repair of electric motor cooling system (the exchange of coolant, hoses, circulation pump)
- the repair of braking system (the exchange of sub pressure pump)
- the repair of car heating system (the exchange of heating elements heater,
- the repair of battery charging system

7.4.The range of diagnosing the powertrain

This area is focused on using the constructed vehicle to conduct work stand and motor research. The suggested research is as follows:

- the operating characteristic of battery charging and discharging allowing determining its efficiency (current, capacity).
- the operating characteristic of electric motor work.
- motor power demand in different working conditions (constant speed, acceleration, barking driving cycles).
- determining the traction characteristic of powertrain.
- determining the speed characteristic of a vehicle,
- the presentation of BLDC controller working principle,
- registration of the torque process and power while acceleration at engine test stand(the characteristic of power on wheels)
- the measurement of retrieving the energy while regenerative braking – road test
- energy consumption while ECE tests

8. The list of requirements

The requirements for the final product which is a car with electric powertrain constructed on the basis of Toyota Starlet will have a significant meaning for the further usage of this vehicle for didactic process. The created list contains all the requirements necessary to ensure the proper functioning of the final product. While the designing works are carried out the functions, features and values given in the functional specification may be changed and the list of requirements constantly modified. The final product will be assessed if it fulfills the requirements. Annex 1 contains the list of requirements that was divided into smaller parts: general

requirements, requirements connected with the maintenance, construction and working principles as well as thermal, voltage measurement systems and requirements connected with safety. The requirements were categorized on the basis of importance level: necessary, suggested and prescriptive.

9. The criteria of accepting the final product

The general criteria of accepting the final product are defined in law regulations such as “Highway Code” and “Vehicle Regulation. The construction changes done on this vehicle should not break these laws.

The vehicle as a whole should be modified to the extent that allows it to function in accordance to the state of contemporary science and technology and of course as it is going to be used for the didactical purposes it should not pose a threat to the user.

Bearing in mind the information stated above the following criteria of accepting the final product may be listed that have to be fulfilled before the final acceptance:

- the vehicle may not pose a direct threat to health or life,
- moving parts must be covered while operating,
- all the parts under voltage must be properly marked and protected against the access of unauthorized person,
- the powertrain must be equipped with all the necessary emergency switches.
- all the components must be produced in such a way that they do not a direct threat of injury because of sharp edges,
- the vehicle must be equipped with safety instruction and technical documentation
- before it is ready to use there must be prepared a document stating that all the modified parts have motor functionality,
- a set of instructions for the basic didactic classes.

10. Planning and implementing the project's effects

The stages of carrying out the project:

1. Functional specification
2. Constructional specification
3. Constructing the vehicle with electric powertrain
4. Modifications that improve the vehicle in reference to its usage
5. Creating a set of practical tasks to determine the construction, working principle, diagnostics and repairs.

11. References

- [1] Glinka T. Maszyny elektryczne wzbudzone magnesami trwałymi, Wydawnictwo Politechniki Śląskiej, Gliwice 2002r.
- [2] Gorczyca Z.: Metody sterowania silników BLDC, Prace naukowe Instytutu Maszyn, Napędów i Pomiarów Elektrycznych Politechniki Wrocławskiej nr 66, Wrocław 2012r.
- [3] Krykowski K.: Silniki PM BLDC w napędzie elektrycznym, analiza, właściwości, modelowanie, Wydawnictwo Politechniki Śląskiej, Gliwice 2011r.

12. Annex

1. The list of requirements for final product

13. List of figures

Fig.1 Regions for electric motor.

Fig. 2. The graph of region changes under overload for synchronous motors.

Fig. 3 The graph of region changes under overload for asynchronous motors.

Fig. 4 The diagram of proposed electric powertrain.

Fig.5 The connection of rotor and stator's winding for BLDC motor.

Fig. 6 Classic steering system of BLDC motor based on the measurement of rotor position with the use of Hall sensors (H1, H2, H3) [2]

Fig.7: Diagram of sensorless steering of BLDC motor.

Fig.8. The diagram of connecting the measurement systems to electrical wiring of an electric vehicle.